

DATA SHEET: TEMBREAK 2 S125-GJ MCCB

MCCB Electrical Characteristics to IEC 60947-2, EN 60947-2, JIS C 8201-2-1 ANN.1, AS/NZS 3947-2, NEMA AB-1

Frame Reference	Quantity	Unit	Condition	TB2 S125
Max In (A) of Frame				125
Model				S125
Number of Poles				3, 4
Type				GJ
Nominal current ratings				
	I_n	(A)	50°C	20, 32, 50 63, 100 125
Electrical characteristics				
Rated operational voltage	U_e	(A)	AC 50/60 Hz DC	690 250
Rated insulation voltage	U_i	(V)		800
Rated impulse withstand voltage	U_{imp}	(kV)		8
Ultimate breaking capacity (IEC, JIS, AS/NZS)	I_{cu}	(kA)	690V AC 525V AC 440V AC 400/415V AC 220/240V AC 250V DC	6 25 50 65 85 40
Service breaking capacity (IEC, JIS, AS/NZS)	I_{cs}	(kA)	690V AC 525V AC 440V AC 400/415V AC 220/240V AC 250V DC	6 22 25 36/33 85 40
Rated breaking capacity (NEMA)		(kA)	480V AC 240V AC	25 85
Protection				
Adjustable thermal, adjustable magnetic Fixed thermal, fixed magnetic Microprocessor Utilisation category				■ A
Installation				
Front connection (FC) Extension bar (FB) Cable clamp (FW) Rear connector (RC) Plug-in (PM) Din rail mounting (DA) Dimensions	height width	(mm) (mm)	3 pole, (1 pole) 4 pole	■ ● ● ● ● - 155 90
Weight	depth weight	(mm) (kg)	3 pole, (1 pole) 4 pole	120 68 1.1 1.4
Operation				
Direct Opening Action Toggle operation Door mounted (HS) / breaker mounted handle (HB) Motor operation (MC)				■ ■ ● ●
Endurance	Electrical Mechanical	cycles cycles	415V AC	30,000 30,000

■ Standard ● Optional - Not Available

DATA SHEET: TEMBREAK 2 S125-GJ MCCB

Outline Dimensions S125-GJ

ASL: Arrangement Standard Line H: Handle Frame Centre Line

Front connected

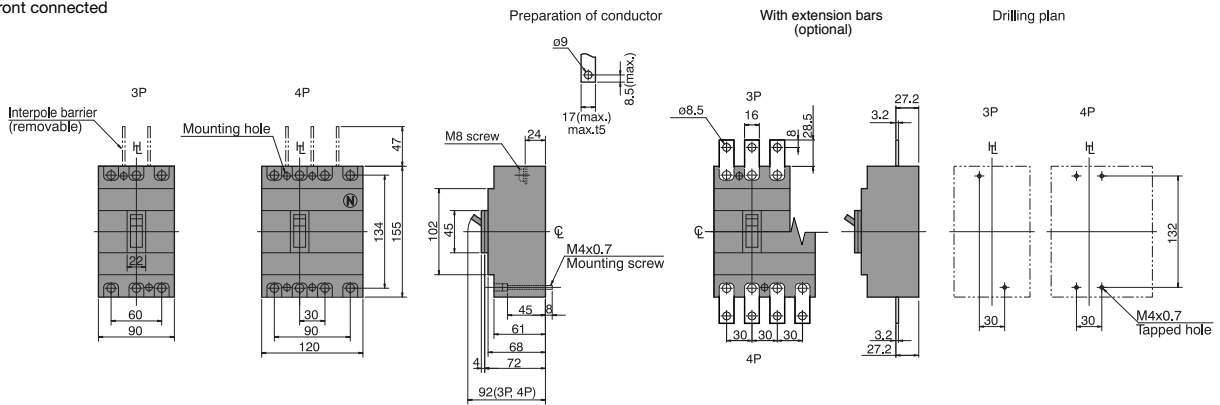

Rear connected

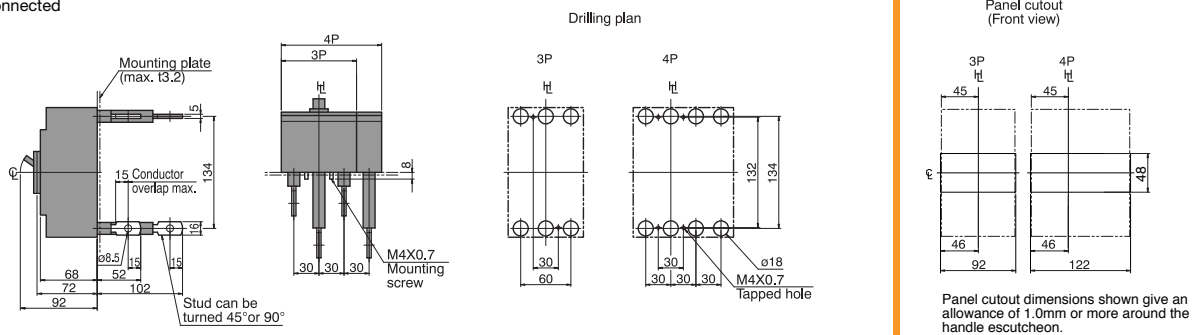

Front connected with Motor Operator

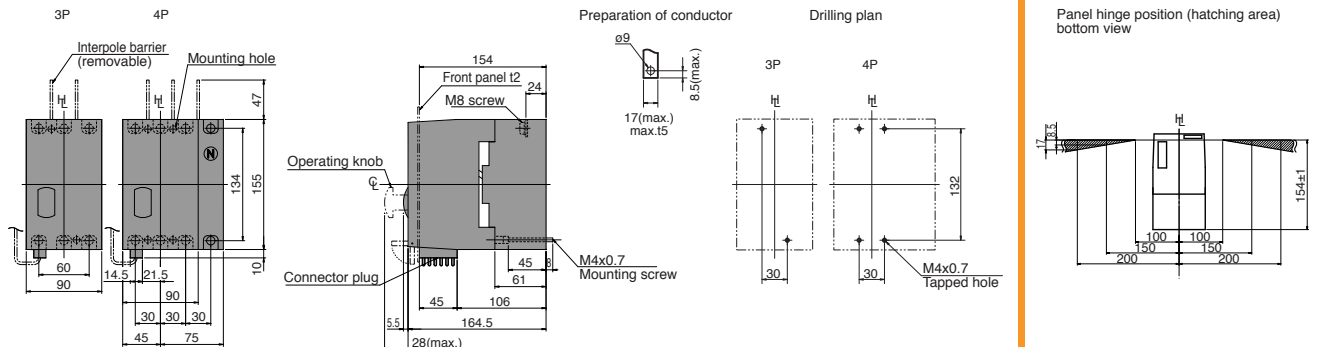

Rear connected with Motor Operator

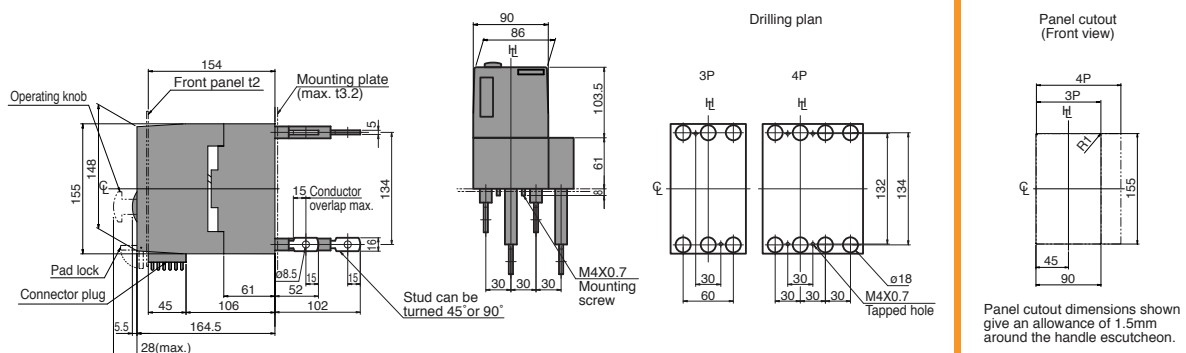

DATA SHEET: TEMBREAK 2 S125-GJ MCCB

Outline Dimensions S125-GJ Plug in Version

ASL: Arrangement Standard Line H_L: Handle Frame Centre Line

Outline Dimensions

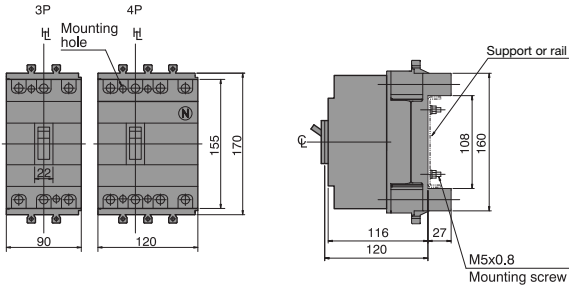

Termination of Busbar

Preparation of conductor

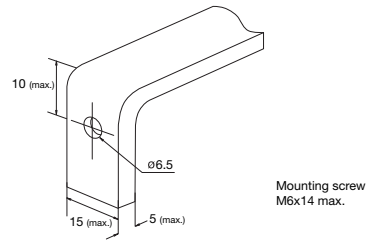

Mounting on a support or rails (shown with optional connection bars oriented for rear access)

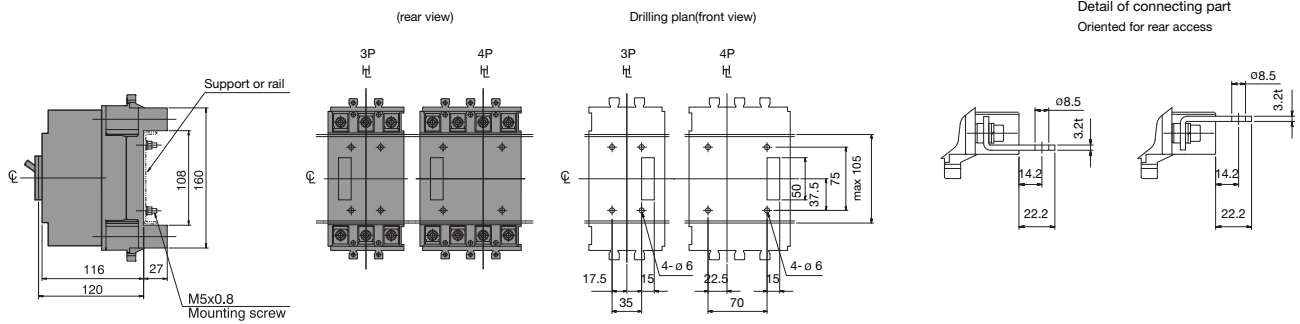

Mounting through the backplate (shown with optional connection bars oriented for rear access)

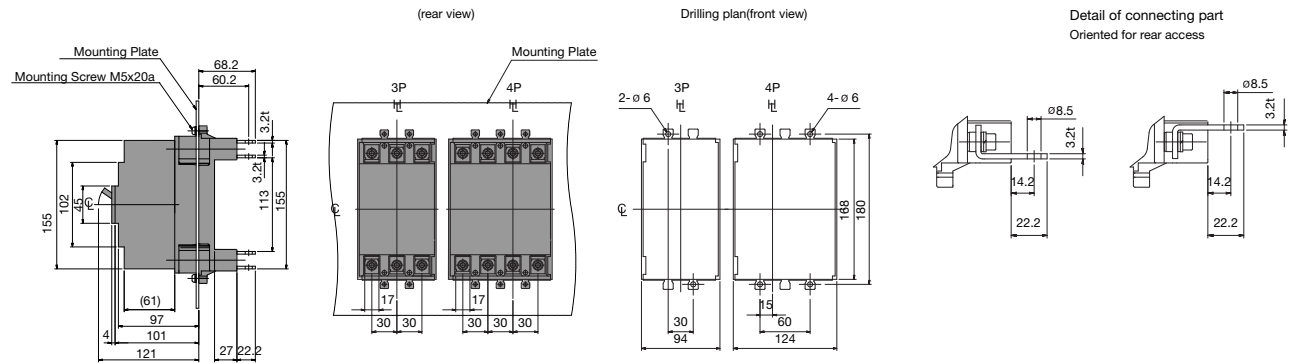

Mounting on the backplate (optional connection bars must be oriented for front access)

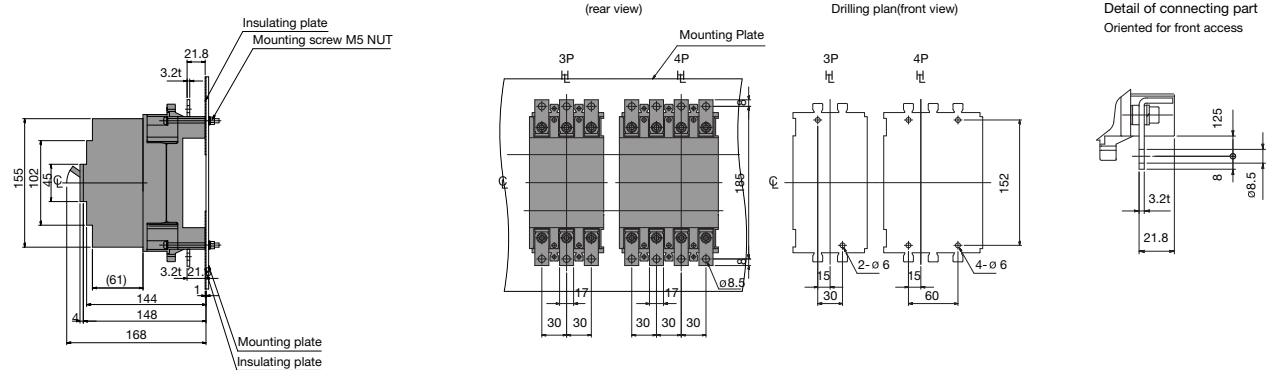

Note that the insulation plate (supplied as standard) must be fitted between the base and the backplate.

DATA SHEET: TEMBREAK 2 S125-GJ MCCB

Time/Current Characteristic Curves

S125-GJ (20A to 100A)

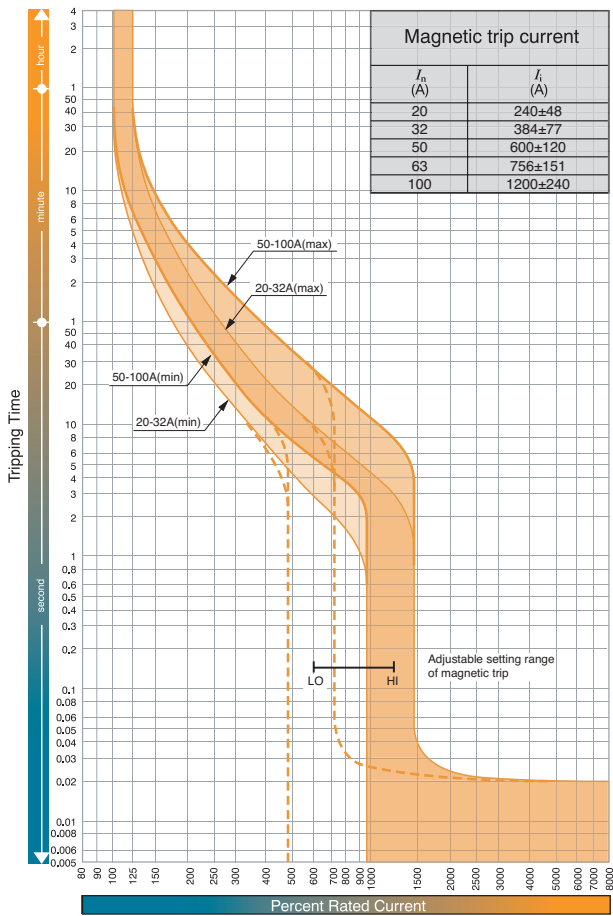

Time/Current Characteristic Curves

S125-GJ (125A)

